

PREFILTER INSTALLATION INSTRUCTIONS

1. If distiller is already installed, shut off water supply at saddle valve or utility faucet connection.
2. Select filter location with the following considerations:
 - a. service accessibility
 - b. adequate tubing length for location
 - c. mounting bracket location (optional)
 - d. protection from excessive heat/freezing
3. Remove filter housing from filter head.
4. If using mounting bracket: Align longer side of bracket over holes in filter head. Attach filter head with 4 screws (*See Illustration*). Using short side of bracket as a template, locate the screw holes on mounting surface. Drill pilot holes and mount bracket with appropriate screws (wood, drywall, metal, concrete, etc.). Screws not included.

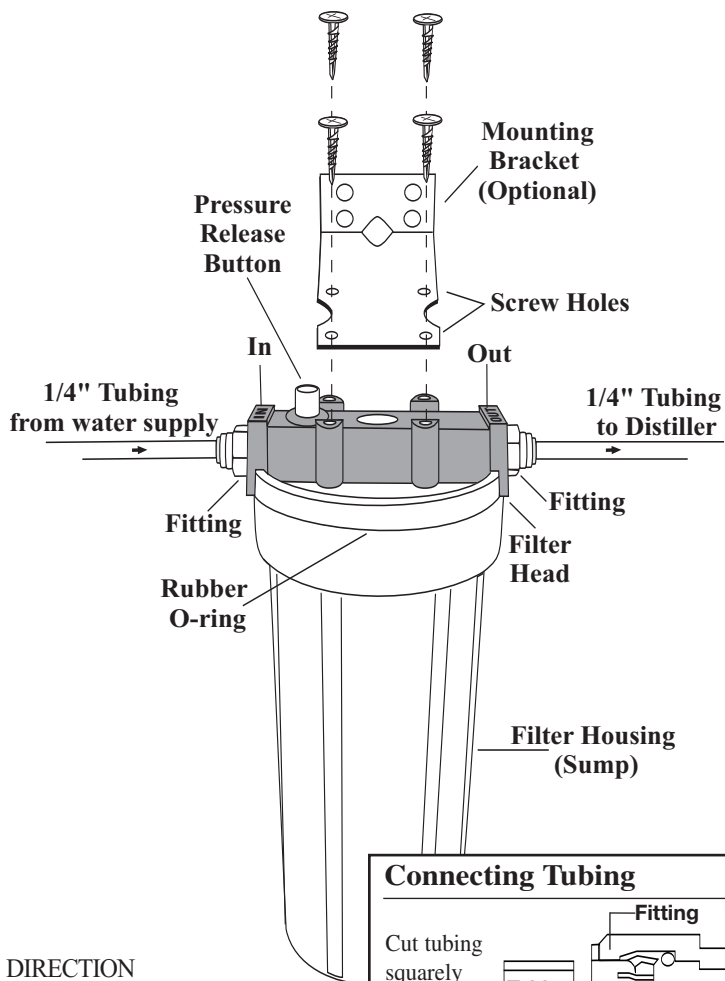

IMPORTANT: BE SURE WATER FLOW DIRECTION IS CORRECT (*See Illustration*).

5. Cut 1/4" tubing squarely. Push tubing from water supply into fitting marked "IN" on filter head. If removal of tubing is necessary, simply pull collet against fitting and pull tubing to release.
6. Connect 1/4" tubing from Distiller into fitting marked "OUT" on filter head. (Allow about 6 feet extra for servicing Distiller.)
7. Insert filter cartridge into filter housing sump. Be sure to remove any protective wrapping (cellophane) from cartridge.
8. Screw filter housing counterclockwise onto filter head. To prevent leaks, be certain the large rubber O-ring is properly seated in groove at top of housing.
9. Open water supply to filter.

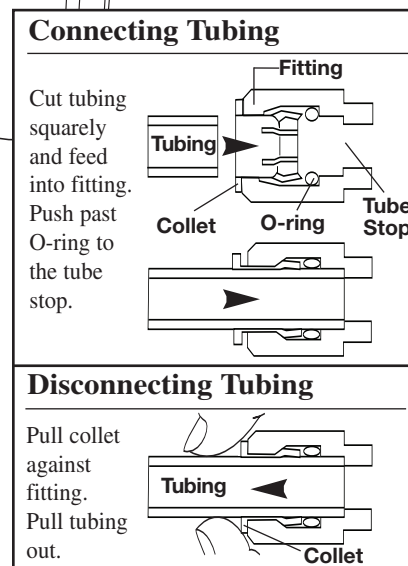

IMPORTANT: Allow 2-3 gallons to flow through carbon cartridge to flush carbon fines, being careful to drain water into nearby sink or washing machine. Connect tubing to Distiller. Check for leaks.

PREFILTER INSTALLATION

PREFILTER CARTRIDGE

Pretreatment consists of an in-line filter housing and carbon filter cartridge. This removes sand, sediment and other suspended particles, reducing maintenance and ensuring more trouble-free operation of your Distiller. Carbon also significantly reduces VOCs (volatile organic contaminants) such as THMs, chlorine, chloroform, pesticides, etc. that may be in some waters. Natural, activated coconut shell carbon is used.

Replace solid carbon block cartridge (#1110) approximately every 1000 gallons or every 9-12 months.

Some water conditions require a more frequent cartridge changing schedule. Never extend cartridge use beyond recommended changing schedule.

TO CHANGE PREFILTER CARTRIDGE

1. Turn off water supply to filter.
2. Depress pressure release button to relieve pressure in filter housing.
3. Unscrew filter housing clockwise from filter head.

NOTE: When opening filter housing to change cartridge, it is common for O-ring to lift out of housing and stick to filter head.

4. Remove used cartridge and discard. Rinse out sump and fill about 1/3 full with water. Add about 2-3 tablespoons of bleach and scrub thoroughly with brush or sponge. Rinse thoroughly.

5. Remove O-ring from filter housing and wipe groove and O-ring clean. Lubricate O-ring with a coating of clean silicone grease. Place O-ring back in place and press O-ring down into groove.

NOTE: This step is important to ensure proper filter seal. Make sure O-ring is seated level in groove.

6. Remove any protective wrapping (cellophane) from new cartridge. Insert and center cartridge into filter housing.
7. Screw filter housing counterclockwise onto filter head and hand tighten. **DO NOT OVERTIGHTEN.**
8. Turn water supply on slowly to allow filter to fill with water.
9. Depress the pressure release button to discharge trapped air from filter.
10. Check for leaks.

DO NOT reuse filter cartridge.

IMPORTANT: Plastic filter housing must be protected against excessive heat/freezing. Failure to do so may result in filter damage and water leakage.

Contact your dealer or call (352) 787-5008 with questions.

Operational maintenance and replacement requirements are essential for product to perform as advertised.