

LONG REACH FAUCET INSTALLATION

IMPORTANT: SAVE THESE INSTRUCTIONS.

BEFORE YOU BEGIN

Read These Instructions Completely and Carefully

- Proper installation is the responsibility of installer.

Tools Needed

- Adjustable wrench.
- Drill with 1/2" high speed bit (if drilling a new hole) suitable for formica top or stainless steel sink. Relton cutter is required for porcelain clad iron sinks.

Prepare for Installation

Select one of the following places to install faucet:

- IN an existing sink spray attachment or soap dispenser hole.
- IN a hole to be drilled in sink top.
- IN a hole to be drilled in countertop, next to sink.

Be sure there is room underneath sink/countertop to make the needed connections.

FAUCET INSTALLATION

- Remove fitting, nut, lock washer and plastic disc from threaded portion of faucet.
- Place threaded end of faucet through hole in sink/countertop positioning it for desired delivery flow location. Make sure large black washer, chrome top washer and small black washer seat flush against sink/countertop.
- From below sink/countertop, secure faucet with plastic disc, lock washer and nut. You may use a wrench on the "flats" of the faucet to hold it in position. Place a cloth between wrench and "flats" to prevent damage to faucet finish.
- Tighten fitting onto threaded portion of faucet.
- Cut 3/8" tubing squarely. Push tubing into fitting as far as it will go (approx. 3/4"). Pull gently on tubing to make sure it is secured. Connect tubing to outlet port of remote faucet pump by fully seating tubing into outlet port fitting (approx. 3/4").
- To dispense water at sink, simply press handle on long reach faucet for instant flow or lift handle for continuous flow. Allow approximately 1 gallon of water to flow through faucet to clear pump system on initial use.
- Turn faucet off and check system for leaks. If any leaks occur turn all switches OFF, unplug the pump box and correct.

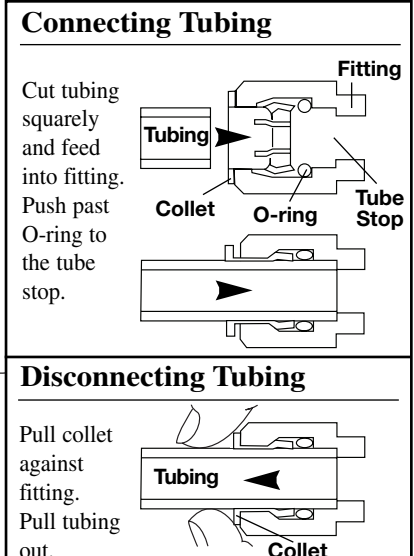
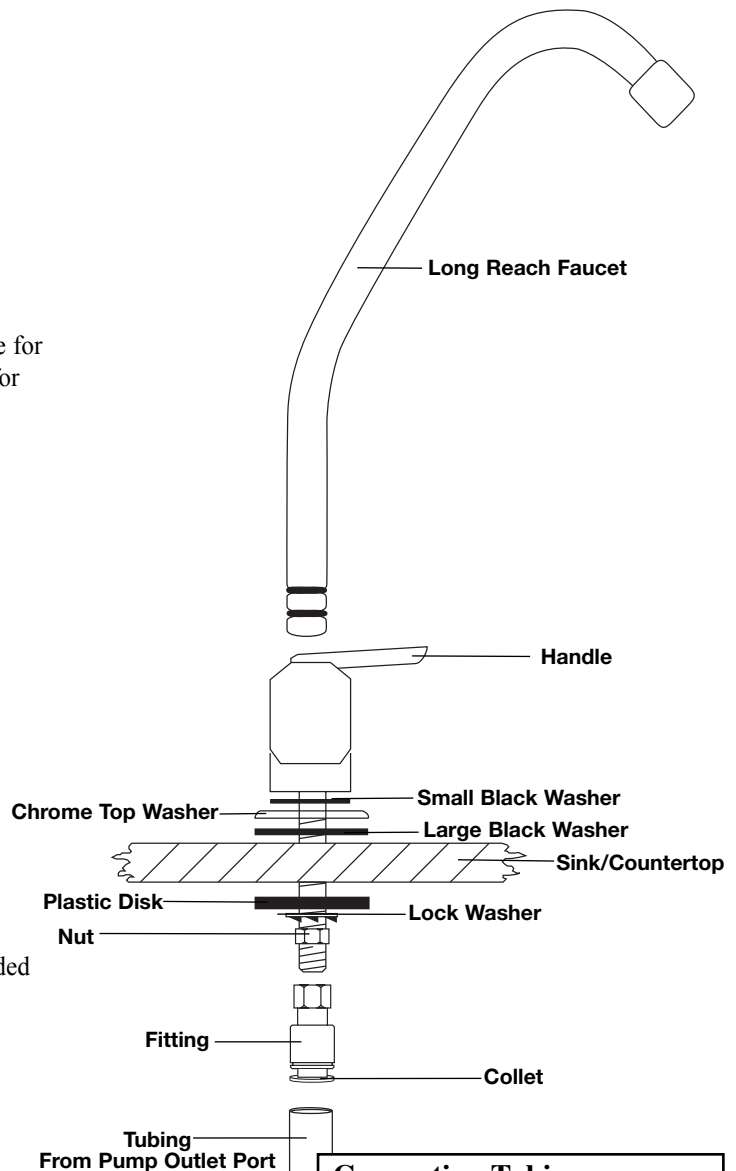

LONG REACH FAUCET INSTALLATION